



Easy Gardening

FERTILIZING • FERTILIZING • FERTILIZING • FERTILIZING

*Joseph Masabni, Assistant Professor and Extension Horticulturist,
and Patrick Lillard, Extension Assistant, The Texas A&M System*

Plants must have light, moisture and nutrients to grow. The sun provides light. Moisture comes from rainfall or irrigation. Nutrients come from fertilizers, compost or manure.

If plants are not growing well, fertilizing them will help only if a lack of nutrients is the cause of the problem. Plants grown in poorly drained soils, in excessive shade, or in competition with tree roots will not respond to fertilizer.

Fertilizers are either organic or inorganic. Examples of organic fertilizers include manure (poultry, cow or horse), bone meal, cottonseed, or other naturally occurring materials. Inorganic fertilizers are manmade products. They usually have a higher nutrient content.

Buying Fertilizers

The three numbers on fertilizer containers are the fertilizer analysis (Fig. 1). They indicate the percent of nitrogen, phosphorus and potassium in the fertilizer, respectively.

These figures are always listed in the same order. So, a 100-pound bag of 10-20-10 fertilizer contains 10 pounds of nitrogen, 20 pounds of phosphorus, and 10 pounds of potassium. This equals a total of 40 pounds of nutrients. The rest of the fertilizer, or 60 pounds in this example, is a carrier or filler such as sand, perlite, or rice hulls. A complete fertilizer is one that includes all three elements.

All parts of a plant need nitrogen for growth—the roots, leaves, stems, flowers and fruits. Nitrogen gives plants their green color and is needed to form protein. A lack of nitrogen causes the lower leaves to turn yellow and the whole plant to turn pale green. On the other hand, too much nitrogen kills plants.



Figure 1. This bag contains 13 percent nitrogen, 13 percent phosphorus, and 13 percent potassium (or potash).

Phosphorus is needed for cell division and to help form roots, flowers and fruit. Phosphorus deficiency causes stunted growth and poor flowering and fruiting.

Plants need potassium for many of the chemical processes that allow them to live and grow. A potassium shortage shows up in various ways, but stunted growth and yellowish lower leaves are common symptoms in many plants.

When you buy fertilizer, consider the cost per pound of the nutrient(s). Generally, higher analysis fertilizers and larger containers are less expensive. For example, a 50-pound bag of 10-20-10 may not cost any more than a 50-pound bag of 5-10-5 fertilizer, but the 10-20-10 bag contains twice the nutrients.

Fertilizer Selection

Most gardeners should use a complete fertilizer with twice as much phosphorus as nitrogen or potassium. An example would be 10-20-10 or 12-24-12. These fertilizers usually are easy to find.

Some soils contain enough potassium for good plant growth and don't need more. But since a slight excess of potassium will not injure plants, it is usually best to use a complete fertilizer.

Do not use lawn fertilizers on gardens. They contain too much nitrogen, and many have chemicals for lawn weed control that can injure or kill vegetables.

Soils with pH levels below 5.7 need lime. Lime adds calcium to the soil and makes it less acidic, raising pH to an acceptable level.

Using Fertilizer

Gardeners should have their soil tested about every 2 years. This is especially important for beginning gardeners who are unfamiliar with growing plants. A soil test clearly

indicates the levels of nutrients in the soil and recommends the amounts of each nutrient to add.

To collect a soil sample, select a time when the soil is moist but not wet. Dig down about 4 to 6 inches and take a handful of soil. Do this in several different places in the garden. Place each handful of soil in a large container and mix. From this mixture, take about ½ pint of soil for the sample (Fig. 2).

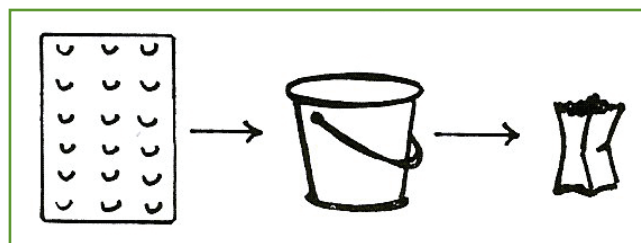

Figure 2. Take soil samples from several areas of the garden and mix them together.

Soil can be tested in midwinter to prepare for spring planting. County Extension agents can give you a soil sample container and explain where to send the sample for testing.

If the garden soil has not been tested, use 2 to 3 pounds of fertilizer such as 10-20-10 for every 100 square feet of garden area. A plot 10 x 10 feet (or 5 x 20 feet)

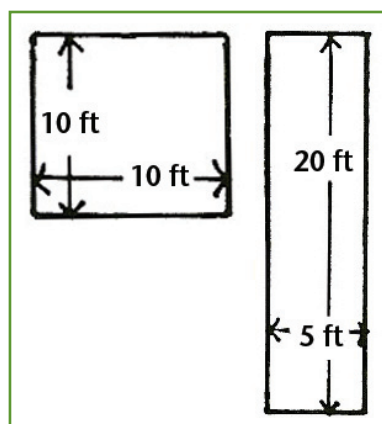

Figure 3. Use 2 to 3 pounds of fertilizer such as 10-20-10 for every 100 square feet of garden area.

square feet (Fig. 3). If a garden is 30 feet long and the rows are 3 feet apart, each row is almost 100 square feet. Use 2 pounds of fertilizer if the garden is sandy and 3 pounds if the soil is mostly clay.

Do not use too much fertilizer. This can kill plants. Two cups of most fertilizers will weigh about 1 pound. If a fertilizer has more nitrogen, use less. Two pounds of 5-10-5 fertilizer supplies as much nitrogen as 1 pound of 10-20-10.

If you are using organic fertilizer such as barnyard manure, spread it evenly over the garden and work it into the soil. Use 20 to 30 pounds of manure for every 100 square feet of garden. Do not use too much. Do not use fresh manure because it can injure plants.

Methods of Applying Fertilizer

Fertilizers are applied four ways:

Broadcast before planting. The proper amount of fertilizer is spread evenly over the garden and mixed with the soil to a depth of 3 to 4 inches before rows are made. This method is the least likely to cause plant damage and usually is best for home gardeners.

Band or row applications. The fertilizer is applied in a strip to the side of the row before planting (Fig. 4). With this method you must be careful to prevent the roots from coming in contact with the fertilizer band,

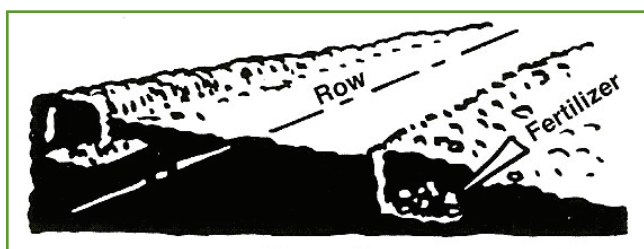

Figure 4. Band or row application of fertilizer.

which can kill plants.

Starter solution. This is used only on transplants such as tomato, pepper, eggplant and cabbage. Mix 2 tablespoons of garden fertilizer in 1 gallon of water and stir well. Pour 1 cup of the mix into the hole and let it soak in before transplanting.

Application to growing plants, or sidedressing. This is especially helpful on sandy soils or when there has been a lot of rain that may have leached nutrients from the soil. Fertilizer is sprinkled along the sides of rows and watered into the soil (Fig. 5). About $\frac{1}{2}$ cup of garden fertilizer for every 10 feet of row usually is enough. The amount and timing of fertilizer needed

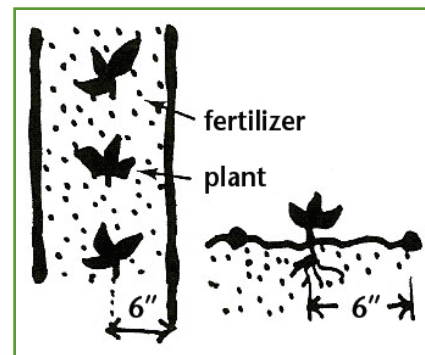

Figure 5. Sprinkle fertilizer along the sides of rows and water it into the soil.

varies according to the type of vegetable planted. Sidedressing increases the yield of most vegetables.

Fertilize fall gardens in the same way as spring gardens. If a fall garden follows a well-fertilized spring garden, you'll need only about half the spring fertilizer rate at planting. Apply 1 to 2 pounds per 100 square feet.

Acknowledgments

The original version of this publication was written by B. Dean McCraw and Sam Cotner.

Information given herein is for educational purposes only. Reference to commercial products or trade names is made with the understanding that no discrimination is intended and no endorsement by the Texas AgriLife Extension Service is implied.

Produced by Texas A&M AgriLife Communications
Extension publications can be found on the Web at AgriLifeBookstore.org
Visit the Texas AgriLife Extension Service at AgriLifeExtension.tamu.edu

Educational programs of the Texas AgriLife Extension Service are open to all people without regard to race, color, sex, disability, religion, age, or national origin.

Issued in furtherance of Cooperative Extension Work in Agriculture and Home Economics, Acts of Congress of May 8, 1914, as amended, and June 30, 1914, in cooperation with the United States Department of Agriculture. Edward G. Smith, Director, Texas AgriLife Extension Service, The Texas A&M System.

New